

# **SUPPLEMENTARY MONSOON CONTINGENCY PLAN**



**APRIL 2009**

**NATIONAL DISASTER MANAGEMENT AUTHORITY**

## **SUPPLEMENTARY MONSOON CONTINGENCY PLAN-09**

**(TO BE READ IN CONJUNCTION WITH NDMA MONSOON CONTINGENCY PLAN-08)**

1. **General.** The peculiar geography, hydrology and the monsoon phenomena, make Pakistan extremely vulnerable to seasonal flooding which has been the most frequently recurring natural disaster in the country. Over the past six decades, floods have cost more than US \$ 5 Billion in economic damages besides causing loss of over 6,000 lives. Emerging weather pattern has further compounded the issue with increased flash flooding in semi-mountainous and mountainous regions and a surge in sea based cyclones. Relative un-preparedness for these hazards has caused significant losses. The latent socio-economic poverty and low disaster awareness levels, more so in the rural regions, declining environmental health, inability to factor risk reduction in development practices, and poor state of disaster preparedness tend to exacerbate the impact of these disasters.

2. The above factors necessitated adoption of a holistic and a well coordinated approach to deal with floods / flash floods in the country in order to minimize economic and human losses for sustained development in the country. In the same context, last year, NDMA initiated a process of consultation with all stakeholders and formulated 'Monsoon Contingency Plan-April 08' The plan undertakes an in depth Hazard Context Analysis, delineates roles and responsibilities of existing Flood Management structure in the country, works out possible Scenarios and conducts a detailed resource mapping at provincial level. It may be mentioned that vulnerability of District Dera Ghazi Khan / Rajanpur and District Peshawar to flash floods (which occurred in August 08) had already been visualized in the relevant sections of the said plan. In accordance with prevalent international practices, 13-15 % of the disaster affected population has been assumed to be in need of relief assistance.

3. A detailed forecast for 'Monsoon-09' is expected to be released by Pakistan Meteorological Department (PMD) by first week of June-09. However, its preliminary assessment for the current year, suggests the following:-

- a. Normal to above normal monsoon rains in the country.
- b. Heaviest snowfall in the past five years in northern regions of the country, thus possibility of:-
  - (1) Early flooding of western rivers (Kabul, Swat etc) as a result of rise in temperature in May-09.
  - (2) Flash floods and land sliding in the vulnerable areas.

4. **Aim.** To carry out review of 'Monsoon Contingency Plan-April 08' in light of preliminary monsoon forecast with a view to updating the plan for coordinating efficient flood management by all stakeholders.

5. **Scope.**

- a. Review of availability / utilization of flood mitigation funds.
- b. Review progress of ongoing flood mitigation projects.
- c. Review of risk analysis in light of preliminary forecast.
- d. Updation of resource mapping.

6. Based upon the dynamics and contributing factors, exacerbating vulnerability to floods in the country, 'Monsoon Contingency Plan-08' (available at [www.ndma.gov.pk](http://www.ndma.gov.pk)) was formulated after excessive consultations with all the stakeholders. The plan provides detailed framework / guidelines for instituting an efficient mechanism for management of flood / monsoon related emergencies in the country. The framework / guidelines remain in force for all response agencies in relation to progress on various flood mitigation projects, monsoon forecast and the available resources at various tiers. Disaster Management Organizational Structure is at Annex A. The current status/update of these variable aspects is covered in the succeeding paragraphs.

7. **Flood Mitigation Projects- FY 2007-08**

a. **Allocation**

Ser	Province / Executing Agency	No of Projects	Allocation (M)	Actual Releases (M)
(1)	Punjab	11	489.807	432.003
(2)	Sindh	06	489.490	244.745
(3)	NWFP	09	203.095	101.550
(4)	Balochistan	17	122.400	61.200
(5)	FATA	09	35.814	22.950
(6)	Northern Areas	05	30.30	15.150
<b>Total</b>		<b>57</b>	<b>1,370.906</b>	<b>877.598</b>

- b. **Projects.** List indicating progress on various flood mitigation projects under PSDP 2007-08 is at Annex-B. A number of projects have either been completed or are nearing completion. However, progress on a significant number is far from satisfactory. The relevant authorities / departments are required to put in concerted and coordinated efforts to ensure that these are completed as early as possible.

8. **Flood Mitigation Projects-FY 2008-09**a. **Allocation**

Ser	Province / Executing Agency	No of Projects	Allocation (M)	Actual Releases (M)
(1)	Punjab	04	382.500	-
(2)	Sindh	01	263.500	131.750
(3)	NWFP	06	93.500	46.750
(4)	Balochistan	18	68.000	-
(5)	FATA	03	25.500	-
(6)	AJ&K	03	8.500	-
(7)	Northern Areas	02	8.500	-
<b>Total</b>		<b>36</b>	<b>850.00</b>	<b>178.500</b>

- b. **Projects.** Details of ongoing and outstanding projects are at Annex–C and D respectively. In view of the paucity of time before the onset of Monsoon Season, it is imperative for the concerned stakeholders to pay special attention for completion of these projects by 30 June 09 in order to achieve desired benefits / protection during the monsoon season.

9. **Possibility of Early Flooding.** Due to heavy snowfall in the northern regions of the country during the last winters (maximum in past five years), there is a likelihood of flooding in Kabul and Swat river systems due to rise in temperature during May 09. This necessitates initiating requisite measures to prevent loss of life and property, including priority completion of related flood mitigation projects along these rivers. Moreover, the increased inflow of water in major reservoirs also needs to be taken into consideration while managing water levels at Tarbela and Mangla Dams to prevent peak synchronization during monsoon rains.

10. **Review of Flood Coordination Meeting-08.** Last NDMA Flood Coordination Meeting was held on 3 May 08. After detailed deliberations during the meeting, specific instructions were issued to concerned authorities / departments for compliance as part of flood mitigation / preparedness measures. Details are as under:-

- a. **Unauthorized Development on Flood Plains.** The rapid urbanization has resulted in unauthorized development activities on the flood plains which cause lot of damage to lives and property during flood season. The concerned regulatory authorities were tasked to strictly prevent such activities and initiate requisite mitigation / preparedness measures to prevent damage to the existing dwellings in the flood plains. However, no significant progress in this regard has been reported as yet.

- b. **Survey of Road Bridges.** National Highways Authority (NHA) was asked to conduct a survey of all road bridges over major waterways, falling on NHA road network to identify any weak areas requiring maintenance. This would preclude any chances of disruption of road communication due to excessive floods. Confirmation in this regard is still awaited from NHA.
- c. **Survey of Railway Bridges.** Similarly, Pakistan Railways was required to conduct survey of all important railway bridges. However, no progress / confirmation by the Railway Authorities has yet been received.
- d. **Urban Flooding.** All major cities of the country (Karachi, Lahore, Rawalpindi, etc) are highly vulnerable to urban flooding during heavy rains / downpour due to obsolete / inadequate drainage system. It has also been observed during the past that people living in the low lying areas faced difficulties and misery because of broken / overflowing of sewerage lines or insufficient / functioning of pumping equipment. The respective city district governments were required to put in concerted efforts in this regard to prevent disruption of routine activities in the cities during monsoon. However, no meaningful progress has been reported as yet.
- e. **Procurement of Flood Relief Equipment / Boats (OBMs).** Sequel to the last Flood Coordination Conference held on 3 May, demand for additional flood relief equipment / boats were forwarded to Provincial Disaster Management Authority (PDMA) Punjab by Headquarters Engineers 2 Corps (Details at Annex-E) and Headquarters Engineers 31 Corps on 17 November 08 and 1 January 09 respectively. However, no progress on this aspect has so far been reported by the concerned PDMA.

#### 11. **Sectoral Tasks / Responsibilities**

- a. **Ministry of Health.** Health response plans at national and provincial level are to be coordinated besides building of adequate reserves of medicines/anti snake viles at the respective levels. Capacity for provision of field hospitals, self contained small medical teams and well equipped blood banks during any disaster situation needs to be developed at priority. Ministry of Health is also required to nominate a Focal Person for health preparedness and response.
- b. **Emergency Relief Cell (ERC).** Augmentation of existing stocks of relief items, through priority procurement is necessary to meet heavy demands

caused by the floods. A rationalized storage pattern is critical to achieve balance in readiness posture.

- c. **National Logistics Cell (NLC)**. NLC being the overall logistics coordinator on behalf of NDMA needs to evolve a comprehensive Disaster Management Logistics Plan to address the complete spectrum of transportation of relief goods across the country, using integral resources, railways, air and hired transport.
- d. **Utility Stores Corporation (USC)**. Services of USC in provision of food items to the flood affectees are of vital importance. Delivery of composite Family Ration Packs, Ready to Eat Meal and other food items through its outlets at short notice is main task for the organization.
- e. **Federal Flood Commission (FFC)**. Ensure efficient management of in/ out flow at Tarbela and Mangla to prevent peak synchronization with monsoon rains in consultation with Pakistan Meteorological Department (PMD).
- f. **Pakistan Meteorological Department (PMD)**.
  - (1) Initiate timely early warnings / weather forecasts to all stakeholders for flash floods in vulnerable regions.
  - (2) Close monitoring of catchment areas of major water reservoirs / rivers and issue of requisite early warnings.
  - (3) Issue timely early warning on unusual high snowmelt due to sudden rise in temperature and its possible flood impact implications
  - (4) Initiate early warning for any impending tropical cyclone to safeguard vulnerable communities
- g. **Provincial Irrigation Departments**. Ensure identification of vulnerable flood protection sites and initiate appropriate remedial measures to prevent failure.
- h. **Provincial Governments**. To undertake followings actions:-
  - (1) Institute integrated planning with regards to search and rescue, provision of food / potable water, shelter health care, livestock support to the flood affectees in the event of an emergency.
  - (2) Update provincial plans for early restoration of severed communication infrastructure (road, rail and telephone) and civic services.

12. **Inventory of Relief Items.** Details of relief items held in stock at various tiers are at Annex-F and G respectively. Requisite measures have been initiated to build stocks of relief items at the federal level. However, concerned authorities at the provincial level are required to pay particular attention to procure and maintain adequate relief items in stock for ensuring provision of prompt relief in the event of a disaster situation.

13. The efficacy of response is not merely dependent on availability of human and material resources. To a large extent, timely initiation of mitigation and preparedness measures determine success of response effort. In this context, quality and quantity of rescue and relief at local level will set the pace for all restorative initiatives. To meet the case, the disaster management stamina at provincial/district levels and equivalent demands immediate up gradation. The wherewithal in federal ministries / provincial departments also needs matching capabilities. A synergized effort is required to confront the looming challenges.

## DISASTER MANAGEMENT ORGANIZATIONAL STRUCTURE

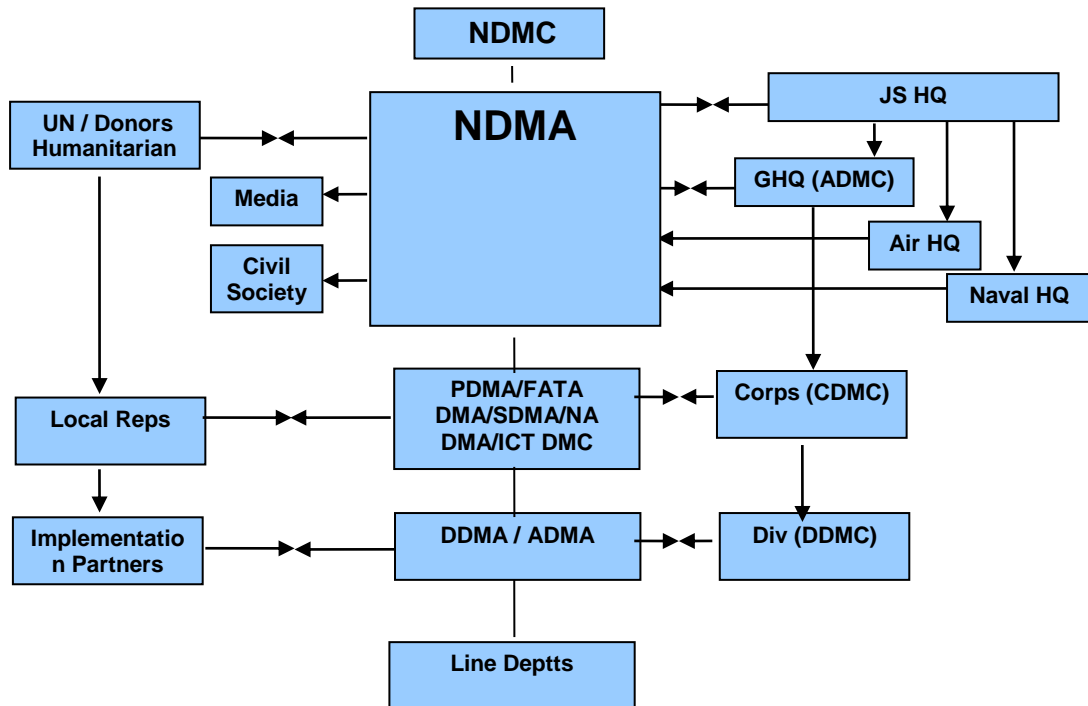

Acronyms	
NDMC	- National Disaster Management Commission
NDMA	- National Disaster Management Authority
ADMC	- Army Disaster Management Cell
CDMC	- Corps Disaster Management Cell
DDMC	- Division Disaster Management Cell
PDMA	- Provincial Disaster Management Authority
SDMA	- State Disaster Management Authority
NADMA	- Northern Area Disaster Management Authority
ICTDMA-	Islamabad Capital Territory Disaster Management Cell
FATA DMA-	Federal Administered Tribal Area Disaster Management Authority



**PROGRESS ON FLOOD MITIGATION PROJECTS**  
**(FY 2007-08)**

<b>Ser</b>	<b>Project</b>	<b>Estimated Cost (in million)</b>	<b>Progress %</b>
<b><u>Punjab</u></b>			
1.	Protecting towns, villages and infrastructure from erosion of River Indus in District Bhakkar	439.747	50 %
2.	Construction of J-Head Spur No.1 on Pir Adil Minor	97.147	97%
3.	Constructing J-Head Spur at RD 10-11 on Colony Protection Bund of Marala Barrage	90.442	40 % work delayed due to court stay
4.	Construction of J-Head Spur RD 170 – 180 on Link No.1	53.114	95 %
5.	Strengthening and rehabilitation of damaged spur/ X-spurs with nose pitching along Chenab Flood Bund and Shujabad Branch	48.660	65 %
6.	Protection measures to save Smoka village and irrigation infrastructure opposite RD 200+000 Minchin Bund	48.560	99%
7.	Strengthening and rehabilitation of Dhundu, Baloch Wah and Gujju Hatta Flood Bund	42.200	70 %
8.	Stone pitching on loop bund river side (Dallas Canal Division)	38.99	80 %
9.	PC-I for Construction of Marchola Flood Protection Bund and Drain in the vicinity of International Boundary on left side of River Tawi	36.443	75 %
10.	Construction of Dohlak Flood Protection Bund and Drain in the vicinity of International Boundary on left side of River Tawi	32.180	75%
11.	PC-I for Construction of Sewaraj Flood Protection Bund and Drain in the vicinity of International Boundary on left side of River Tawi	19.130	75 %
<b>Total</b>		<b>946.613</b>	
<b><u>Sindh</u></b>			
1.	Raising/strengthening, stone pitching along F.P Bund RD 169 to 263.5 & RD 502 to 120	492.236	50 %
2.	Raising/strengthening, stone pitching along Suprio Bund RD 0 to 95	253.181	60 %
3.	Constructing stone apron & stone pitching along Bakhri Loop Bund mile 0/3 to 1/6	101.752	100 %
4.	Stone pitching with Toe wall along M.S. Bund mile 18/0 to 22/0	38.074	100 %
5.	Stone pitching with apron along S.H Bund from mile 0/3 to 1/6	34.640	100 %
6.	Recouperment of T-head spur at S.M. Bund mile 135/7+500 to 136/0+200	16.178	100%
<b>Total</b>		<b>936.061</b>	
<b>Ser</b>	<b>Project</b>	<b>Estimated</b>	<b>Progress</b>

		<b>Cost (in million)</b>	<b>%</b>
<b><u>NWFP</u></b>			
1.	Construction of three spurs on Kurram River near Pinjama in District Lakki Marwat	34.80	60 %
2.	Construction of flood protection structures at critical locations on different rivers and local khwars/nullahs in Swat, Buner, Shangla, Battagram, Mansehra, Abottabad & Haripur Districts	29.00	84 %
3.	Construction of flood protection scheme at critical location along different rivers/Nullahs in District D.I.Khan & Tank	27.306	90 %
4.	Construction of flood protection structures at critical locations on different rivers and local nullahs in District Charsadda, Mardan & Swabi	26.47	90 %
5.	Construction of flood protection works for the protection of villages and other infrastructure at critical locations in District Nowshera	26.00	92 %
6.	Protection scheme at critical location along different rivers/nullahs in District Lakki Marwat & Bannu	24.103	80 %
7.	Construction of flood protection works for the protection of various abadies and other infrastructure at critical locations in Peshawar, Kohat, Karak & Hangu Districts	23.00	89 %
8.	Construction of flood protection works at vulnerable locations along different rivers & local nullahs in District Dir (Lower/Upper) Chitral	22.00	95 %
9.	Construction of flood protection works for the villages and agricultural lands from floods in Jambi/Marghuzar Khwars, District Swat	2.00	90 %
<b>Total</b>		<b>214.679</b>	
<b><u>Balochistan</u></b>			
1.	PC-I/Estimate for 9 x Flood Protection schemes in Killa Saifullah District	22.20	96 %
2.	PC-I/Estimate for flood protection bunds for villages and agriculture lands/orchards in District Kalat/Washuk	16.00	85 %
3.	Construction of Flood Protection Bund Sami District Kech	11.647	32%
4.	Construction of 4 x. flood protection schemes in Districts Kech, Panjgur	10.50	100 %
5.	PC-I/Estimate for 7 x Flood Protection schemes in Sherani & Zhob Districts	9.60	100 %
6.	PC-I/Estimate for construction of 3 x flood protection bunds for villages and agricultural lands/orchard in District Khuzdar	8.20	80 %
7.	PC-I/Estimate for 4 x Flood Protection schemes in Musa Khel & Loralai Districts	8.20	93 %
8.	PC-I/Estimate for construction of 3 x flood protection bunds in District Kharan	7.50	80 %
9.	PC-I/Estimate for 5 x flood protection schemes in Sibi, Harnai & Ziarat Districts	7.30	60%

Ser	Project	Estimated Cost (in million)	Progress %
10.	PC-I for 4 x Flood Protection schemes in Quetta, Chagai & Nushki Districts	6.50	83%
11.	Umbrella PC-I/Estimate for 2 x flood protection schemes in Kulachi Village and Mushkaf town District Bolan	5.00	100 %
12.	Construction of protection bund for Moosani Village Bela, District Lasbela	4.00	100 %
13.	PC-I/Estimate for 2 x Flood Protection schemes in Pishin & Killa Abdullah Districts	3.40	100 %
14.	Construction of flood protection bund along Ayoub Dhora/River at Hub District Lasbela	3.00	22 %
15.	PC-I/Estimate for construction of flood protection bunds for villages and agricultural lands orchards in District Awaran	3.00	100 %
16.	PC-I/Estimate for Flood Protection scheme of Killi Dad Mohammad Zarkoon Uryani (Harini) area District Kohlu	2.90	100 %
17.	Construction of remaining portion Flood Protection Bund Jhal Magsi Town in District Jhal Magsi	2.85	100 %
<b>Total</b>		<b>131.797</b>	
<b>FATA</b>			
1.	Flood protection scheme for village abadies & culturable land in Kajori Bara Tehsil Khyber Agency	6.00	100 %
2.	Flood protection scheme for protection of culturable land & village abadies of Razi Khan Hach and Lal Gul Hussan Khel near Morrgha Village Sherani area F.R D.I. KHAN	4.704	100%
3.	Flood protection scheme of Bimber Nazar Khel Tangari and Tormandi in Sarwakai Tehsil S.W. Agency	4.449	100 %
4.	Flood protection & reclamation of land & village abadies for Ozee villages in Upper Kurram Agency	4.266	64 %
5.	Flood protection scheme for protection of land of Anayat Khan Kach at Hamzoni in Miranshah Tehsil N.W. Agency	4.00	100 %
6.	Flood protection scheme for Tochi River for protection of village abadies and culturable land of Ziraki area in Mirali Tehsil N.W. Agency	4.00	100 %
7.	Flood protection scheme for protection of Behran Kach Teran on right side of Wana Algad Tehsil Wana South Waziristan Agency	3.10	100 %
8.	Flood protection scheme for protection of abadies and agricultural land on right side of Woucha Dhana Algad in Shah Alam area, Tehsil Birmal, South Waziristan Agency	2.999	100 %
9.	Flood protection scheme for the village settlement abadies in Jamal-u-Din Kach Pir Tani Area F.R. Tank	2.296	100%
<b>Total</b>		<b>35.814</b>	

Ser	Project	Estimated Cost (in million)	Progress %
<b><u>AJ&amp;K</u></b>			
1.	Nil		
<b><u>Northern Areas</u></b>			
1.	Flood Protection and River Training Works for Darel/Tangir Valley	30.900	-
2.	Construction of flood protection bund at Salling District Ghanche	20.678	60 %
3.	Construction of flood protection bund at Gahkuch Silpi, Sandi, Sultanabad, Yasin and Ghizer District	14.540	90 %
4.	Construction of protection bund at Usmanabad Basin Gilgit	7.135	75 %
5.	Construction of protection bund at Surmo District Ghanche	3.639	60 %
<b>Total</b>		<b>76.892</b>	
<b><u>I.C.T</u></b>			
1.	Nil		

**ONGOING FLOOD MITIGATION PROJECTS**  
**(FY 2008-09)**

<b>Ser</b>	<b>Project</b>	<b>Estimated Cost (Rs in Million)</b>
<b><u>Punjab</u></b>		
1.	Constructing J-Head Spur # 2 of Pir Adil Minor & I-L Disty of Link No.1	141.497
2.	Construction of Guide Head Spur at RD 165+000 Link No.1	53.033
3.	Providing protective measures Muhammad Shahwala Flood Bund and Burala Branch against erosion by River Ravi (Guide Spur at RD 419+000 of Burala Branch)	50.391
4.	Construction of sloping studs/Lunda Bund against erosion action of Chenab River to protect Tombs of Ameer Shah, Wali Ullah Boray Shah and abadies etc.	10.723
<b>Total</b>		<b>255.644</b>
<b><u>Sindh</u></b>		
1.	Extension of stone apron & pitching along K.K. Bund Mile 11/3 to 12/4 and re-coupmnt of damage stone apron and pitching from Mile 10/7+500 to 11/1+110	268.549
<b><u>NWFP</u></b>		
1.	Construction of Spur No.34 along right bank of River Indus District D.I.Khan	198.752
2.	Construction of flood protection structures at critical locations on different Khwars and Nullahs in District Mardan	39.000
3.	Construction of flood protection work at critical locations in District Nowshera & Swabi	33.00
4.	Construction of flood protection work for village Mohib Banda, Banda Sheikh Ismail and adjoining area District Nowshera	19.00
5.	Construction of flood protection works along Panjkora River and Maidan Kuhnai Khawar in District Dir Lower	7.36
6.	PC-II of River Survey and Model Study of River Indus D/S of Dera Darya Khan Bridge, District D.I.Khan to Punjab Boundary	6.339
<b>Total</b>		<b>303.451</b>

Ser	Project	Estimated Cost (Rs in Million)
<b>Balochistan</b>		
1.	Raising/Strengthening and Completion of remaining work of Flood Protection Bund Jhal Magsi Town, District Jhal Magsi	13.137
2.	Construction of flood protection bund for agriculture coconut farm Tehsil Uthal District Lasbella	12.000
3.	Construction of Gabion Spurs for Adjoining villages of Harnai Area and flood protection of Raisani Bund District Ziarat & Harnai	5.450
4.	(a) Flood protection of Tora Deraga for Protection of Agriculture Lands of Muhammad Ibrahim Awara & others, District Zhob (b) Flood protection of new Abadies of Sheikhan Town Zhob (Right Bank of Zara Ghoundai Stream) District Zhob (c) Flood Protection of Agriculture Land/Houses of Wouchaba & Killi Tore Shah in Badinzia area, District Zhob (d) Flood Protection Agriculture Lands of Kach Mir Adam & others in Kapip Sherani area, District Zhob (e) Flood Protection of agricultural lands of Mallawar area (Khabul Khan & others) District Zhob	4.300
5.	(a) Flood Protection of Mithri Village District Kachhi (b) Flood Protection of Dopasi village District Kachhi	4.000
6.	(a) Flood Protection of Agricultural Land D/S of Seakle Flood Irrigation Scheme, District Barkhan. (b) Flood Protection of People Colony & F.C. Colony Kohlu Town, District Kohlu.	3.876
7.	Construction of Flood Protection Bund for Agriculture Land Mouza Machian U/C Sarwan District Kharan	3.600
8.	Construction of Gabion Spurs Garuk, Nal area District Khuzdar	3.211
9.	(a) Construction of Flood Protection Scheme Kamalzai District Pishin (b) Construction of Flood Protection Scheme Killi Old Shakarzai, District Pishin (c) Construction of Flood Protection Scheme Orchards/Lands Killi Abdullah Jan Takari Manda Toba Achakzai, District Killa Abdullah	3.000

<b>Ser</b>	<b>Project</b>	<b>Estimated Cost (Rs in Million)</b>
10.	(a) Flood Protection of houses & orchards in Margat area in Quetta, District Quetta  (b) Flood protection of Killi Asiawan area in District Nushki  (c) Flood protection of Dalbandin Airport in District Chaghi	3.000
11.	Construction of Flood Protection Bund/Wall Khalique-abad Mangocher area District Kalat	2.500
12.	Flood Protection of Khaddal for agricultural land of Killi Haji Noor Mohammad Guldad and others Killi Sherra Tehsil Droog District Musa Khel	2.481
13.	(a) Flood Protection of Agricultural Land of Killi Azam Abad Mahool Tehsil Bori District Loralai  (b) Flood Protection of Agricultural Land of Killi Abdul Wahab & others Toisar area District Musakhail	2.000
14.	Construction of Koshk River Flood Protection near Cotton Factory Khuzdar, District Khuzdar	2.000
15.	Flood Protection of Lasbella Canal at RD 76+200 District Lasbella	1.500
16.	Extension of Mohamoadani Flood Protection Bund Bela District Lasbela	1.500
17.	(a) Flood Protection of Agriculture Land & Abadies of Kach Khair Muhammad & others in Nasai area, District Killa Saifullah  (b) Flood Protection of Agriculture Land & Abadies of Haqdad Awara Alozai & others in Alozai area, District Killa Saifullah.	1.400
18.	Construction of flood protection PCC Wall Chamrok at Gualoo Jhal, Khuzdar Town, District Khuzdar	0.700
	<b>Total</b>	<b>69.655</b>
<b><u>FATA</u></b>		
1.	Flood protection scheme at Qalandar Gurbaz F.R. Bannu	3.50
2.	Flood protection scheme for protection of culturable land and village of Zarif Koroona Killi Tehsil Ekkaghuan Mohmand Agency	2.668
3.	Flood protection scheme near Lashta Mir Kot from the action Nungar Algad (Phase-I, F.R. Lakki	2.50
	<b>Total</b>	<b>8.668</b>

Ser	Project	Estimated Cost (Rs in Million)
<b><u>Azad Jammu &amp; Kashmir</u></b>		
1.	Protecting & checking of erosion against flood along left edge of River Mahl near Bhount Chowk in District Bagh	13.575
2.	Protecting & checking of erosion against flood on the left bank of River Jhelum, near Government College Garhi Dupatta District Muzaffarabad	5.68
3.	Protecting & checking of erosion against flood along left edge of River Punch at Mandi Kotli area, District Kotli	4.10
<b>Total</b>		<b>23.355</b>
<b><u>Northern Areas</u></b>		
1.	Construction of protective bund at Saling (Phase-II)	12.786
2.	PC-II for Comprehensive Hydraulic Modelling of Shyoke River District Ghance	4.00
<b>Total</b>		<b>16.786</b>



**IMPENDING FLOOD MITIGATION PROJECTS**  
**(FY 2008-09)**

<b>Ser</b>	<b>Project</b>	<b>Estimated Cost (Rs in Million)</b>
<b><u>Punjab</u></b>		
1.	Construction of River Training/Protection Works along Link No.1 between RD 144 +000 to RD 167+000 in D.G. Khan District	199.975
2.	Construction J-head Spur No.1-L Disty of Link	71.917
3.	Constructing J-head Spur No.2 of Pir Adil Minor	60.520
4.	Providing protective measures to Muhammad Shahwala Flood Bund and Burala Branch against erosion of River Ravi (Guide Spur at RD 419+000 of Burala Branch	49.360
<b>Total</b>		<b>381.772</b>
<b><u>Sindh</u></b>		
1.	Extension of stone apron & pitching along K.K. Bund Mile 11/3 to 12/4 and re-coupmnt of damage stone apron and pitching from Mile 10/7+500 to 11/1+110	268.549
<b><u>NWFP</u></b>		
1.	Construction of Spur No.34 & 35 along right bank of River Indus District D.I.Khan	203.326
2.	Construction of flood protection structures at critical locations on different Khwars and Nullahs in District Mardan	39.016
3.	Construction of flood protection work at critical locations in District Nowshera & Swabi	33.00
4.	Construction of flood protection work for village Mohib Banda, Banda Sheikh Ismail and adjoining area District Nowshera	19.00
5.	Construction of flood protection work at critical locations in Peshawar & Hangu Districts	13.00
6.	Construction of flood protection works along Panjkora River and Maidan Kuhnai Khawar in District Dir Lower	7.36
<b>Total</b>		<b>314.702</b>
<b><u>Balochistan</u></b>		
1.	Raising/Strengthening and Completion of remaining work of Flood Protection Bund Jhal Magsi	13.200
2.	Flood protection bund for agriculture coconut farm Uthal District Lasbella	12.000
3.	Construction of Gabion Spurs for Adjoining villages of Harnai Area and Flood protection of Raisani Bund District Ziarat	5.450

Ser	Project	Estimated Cost (Rs in Million)
4.	(a) Protection of Tora Deraga for Protection of Agriculture Lands of Muhammad Ibrahim Awara & others, District Zhob (b) Protection of new Abadies of Sheikhan Town Zhob (Right Bank of Zara Ghounddai Stream) District Zhob (c) Flood Protection of Agriculture Land/Houses of Wouchaba & Killi Tore Shah in Badinzia area, District Zhob (d) Flood Protection Agriculture Lands of Kach Mir Adam & others in Kapip Sherani area, District Zhob (e) Flood Protection of Killi Mallawar Khabul Khan District Zhob	4.300
5.	(a) Flood Protection of Mithri Village District Kachhi (b) Protection of Dopasi village District Kachhi	4.000
6.	(a) Flood Protection of Agricultural Land D/S of Seakle Flood Irrigation Scheme Barkhan, Distt. Kohlu (b) Flood Protection of People Colony & F.C. Colony Kohlu Town	3.876
7.	Protection Bund for Agriculture Land Mouza Machian District Kharan	3.600
8.	Construction of Gabion Spurs Garuk, Nal area District Khuzdar	3.211
9.	(a) Flood Protection of Houses & orchards in Margat area in Quetta, District Quetta (b) Flood protection of Killi Asiawan area in District Nushki (c) Flood protection of Dalbandin Airport in district Chaghi	3.000
10.	(a) Construction of Flood Protection Scheme Kamalzai District Pishin (b) Construction of flood Protection scheme Killi old Shakarzai, District Pishin (c) Construction of Flood Protection scheme Orchards/ Lands Killi Abdullah Jan Takari Manda Toba Achakzai, District Killa Abdullah	3.000
11.	Khalique-abad Flood Protection Bund, Mangocher area District Kalat	2.500
12.	Flood Protection of Khaddal for agricultural land of Killi Haji Noor Mohammad Guldad and others Killi Sherra Tehsil Droog District Musa Khel	2.481

<b>Ser</b>	<b>Project</b>	<b>Estimated Cost (Rs in Million)</b>
13.	Koshk River Flood Protection near Cotton Factory Khuzdar, District Khuzdar	2.000
14.	(a) Flood Protection of Agricultural Land of Killi Azam Abad Mahool Tehsil Bori District Loralai (b) Flood Protection of Agricultural Land of Killi Abdul Wahab & others Toisar area District Musakhail	2.000
15.	Rehabilitation of Mohamoadani Flood Protection Bund Bela District Lasbela	1.500
16.	Flood Protection of Lasbella Canal at RD 76+200 District Lasbella	1.500
17.	(a) Flood Protection of Agriculture Land & Abadies of Kach Khair Muhammad & others in Nasai area Tehsil Muslim Bagh (b) Flood Protection of Agriculture Land & Abadies of Haqdad Awara Alozai & other in Alozai area Killa Saifullah.	1.400
18.	Gualoo Jhal Chamrok Flood Protection Khuzdar Town, District Khuzdar	0.700
<b>Total</b>		<b>69.911</b>

<b><u>FATA</u></b>		
1.	Flood protection scheme at Qalandar Gurbaz F.R. Bannu	3.50
2.	Flood protection scheme for protection of culturable land and village of Zarif Koroona Killi Tehsil Ekkaghuand Mohmand Agency	2.668
3.	Flood protection scheme near Lashta Mir Kot from the action Nungar Algad (Phase-I, F.R. Lakki	2.50
<b>Total</b>		<b>8.668</b>
<b><u>Azad Jammu &amp; Kashmir</u></b>		
1.	Protecting & checking of erosion against flood along left edge of River Mahl near Bhount Chowk in District Bagh	13.575
2.	Protecting & checking of erosion against flood on the left bank of river Jhelum, near Government College Garhi Dupatta District Muzaffarabad	5.68
3.	Protecting & checking of erosion against flood along left edge of River Punch at Mandi Kotli area, District Kotli	4.10
<b>Total</b>		<b>23.355</b>

Ser	Project	Estimated Cost (Rs in Million)
<b><u>Northern Areas</u></b>		
1.	Construction of protective bund at Saling (Phase-II)	12.786
2.	PC-II for Comprehensive Hydraulic Modeling of Shyoke River District Ghance	4.00
<b>Total</b>		<b>16.786</b>

**ADDITIONAL DEMAND**

Ser	Item with Complete Specification	A/U	Deficient Quantity		Total Demand
			Against Survey Board	Critical / Essential	
<b><u>Okara</u></b>					
1.	OBM 30 HP Yamaha	Nos	-	9	9
2.	Gen Set 2.5 KVA	Nos	-	2	2
3.	Fuel Line with Adopter 40/30 HP	Nos	-	8	8
4.	Impeller 30 HPP Yamaha	Nos	-	8	8
5.	Accelerator Cable	Nos	2	-	2
6.	Starting Rope	Nos	3	-	3
7.	Cigarette Lighter	Nos	7	-	7
8.	Sheer Pin OBM 20/25	Nos	3	-	3
9.	Sheer Pin OBM 30 HP	Nos	1	-	1
10.	Sheer Pin OBM 40 HP	Nos	2	-	2
11.	Sparking Plug OBM 20/25 HP	Nos	2	-	2
12.	Sparking Plug OBM 30 HP	Nos	1	-	1
13.	Sparking Plug oBM 40 HP	Nos	2	-	2
14.	Sparking Plug OBM 55 HP	Nos	1	-	1
15.	Sparking Plug OBM 20/25 HP	Nos	2	-	2
16.	Sparking Plug OBM 30 HP	Nos	2	-	2
17.	Sparking Plug OBM 55 HP	Nos	1	-	1
18.	Propeller OBM 20/25 HP	Nos	1	-	1
19.	Propeller OBM 30 HP	Nos	1	-	1
20.	Propeller OBM 40 HP	Nos	1	-	1
21.	Propeller OBM 55 HP	Nos	1	-	1
<b><u>Multan</u></b>					
1.	Life Jackets 36/40	Nos	14	-	14
2.	High Tension Lead	Nos	20	-	20
3.	Accelerator Cable	Nos	5	-	5
4.	Sparking Plug 30 HP	Nos	7	-	7

Ser	Item with Complete Specification	A/U	Deficient Quantity		Total Demand
			Against Survey Board	Critical / Essential	
5.	Sparking Plug 40 HP	Nos	14	-	14
6.	Starting Rope	Nos	11	-	11
7.	Fuel Line OBM 40 HP	Nos	2	4	6
8.	Paddle	Nos	-	92	92
9.	Bailer	Nos	-	7	7
10.	Boat Hook	Nos	-	23	23
11.	Buoy	Nos	-	7	7
12.	Fuel Tank OBM 25 HP	Nos	-	6	6
<b><u>Abdul Hakim</u></b>					
1.	Fuel Filter for OBM 25 HP	Nos	3	-	3
2.	Battery 12 Volt with carrying Case	Nos	1	-	1
3.	Spanner Socket	Nos	10	-	10
4.	Spanner 10 x 12	Nos	2	-	2
5.	Pliers Japan	Nos	2	-	2
6.	Screw Driver	Nos	3	-	3
7.	Ring Spanner 12 x 14	Nos	1	-	1
8.	Sand Bags	Nos	985	-	985
9.	Life Ring	Nos	5	-	5
10.	Plastic Water Cane 12 Gals	Nos	1	-	1
11.	Tool Bag	Nos	5	-	5
12.	Starting Chock for OBM 25 HP	Nos	-	5	5
13.	Starting Chock Accessories for OBM 25 HP	Nos	-	5	5
<b><u>Multan</u></b>					
1.	Boat Yamaha Fiber Glass	Nos	-	10	10
2.	Bouys 24 Gauge	Nos	-	52	52
3.	Bailer	Nos	-	58	58
4.	Boat Hook	Nos	-	65	65
5.	Fuel Line OBM	Nos	-	03	03
6.	Fuel Tank OBM	Nos	-	01	01
7.	Search Lights	Nos	-	35	35

Ser	Item with Complete Specification	A/U	Deficient Quantity		Total Demand
			Against Survey Board	Critical / Essential	
8.	Paddle Long Fiber	Nos	-	130	130
9.	Rope Nylon (6 meter)	Nos	-	65	65
10.	Grease Gun	Nos	-	02	02
11.	Oil Pump	Nos	-	02	02
12.	Tool kit	Nos	-	65	65
13.	Rope Nylon ( Meter ) Rain	Nos	-	65	65
<b><u>Abdul Hakim</u></b>					
1.	Anchor Boat	Nos	-	21	21
2.	Bouy Anchor	Nos	-	21	21
3.	Baler	Nos	-	21	21
4.	Paddle Boat	Nos	-	190	190
5.	Rein 15 Meter	Nos	-	84	84
6.	Life Ring	Nos	-	21	21
7.	Boat Hook	Nos	-	21	21
8.	Flood Light	Nos	-	10	10
9.	Sparking Plug OBM's	Nos	-	25	25
10.	Empaler of OBM 25 HP YAMAHA	Nos	-	02	02
11.	Propeller for OBM 30 HP YAMAHA	Nos	-	10	10
12.	Accelerator for OBM 30 HP YAMAHA	Nos	-	10	10
13.	Fuel Filter OBM 55 HP	Nos	-	02	02
14.	Paul / Paul Spring for OBM 25 HP	Nos	-	08	08
15.	Ratchet Spring for OBM 25.30 & 40 HP	Nos	-	03	03
16.	Sher Pin for OBM 25 HP	Nos	-	02	02
17.	Split Pin	Nos	-	20	20

**REPLACEMENT DEMAND**

<b>Ser</b>	<b>Unit with Location</b>	<b>Items</b>	<b>Quantity</b>
1.	Okara	OBM's 15 HP	9
2.	Multan	OBM's 15 HP	8
3.	Abdul Hakim	OBM's 15 HP	19
4.	Multan	OBM's 15 HP	20
<b>Total</b>			<b>56</b>



**SUMMARY OF STOCK POSITION RELIEF ITEMS**

Ser	Items	ERC			Quetta	AJ&K	NAs Gilgit	Total
		Isb	Kci	Lhr				
1.	Tents	2003	3524	3520*	2000	1900	547	13494*
2.	Blankets	-	2090	-	-	-	2689	4779
3.	Plastic Mats	1,25,235	57805	-	-	6000	1388	1,90,428
4.	Plastic Sheets	285	-	-	-	-	-	285
5.	Net Mosquito	204	-	-	-	-	-	204
6.	Warm Jackets	7727	-	-	-	-	-	7727

\*3413 Tents are unserviceable

**SUMMARY OF STOCK POSITION RELIEF ITEMS - NGOs/INGOs****PRCS**

	<b>NHQ</b>	<b>Balochistan</b>	<b>Sindh</b>	<b>Punjab</b>	<b>NWFP</b>	<b>AJK</b>	<b>NA</b>	<b>FATA</b>	<b>Mansehra</b>	<b>Total</b>
<b>Tents</b>	14985	22082	5787	4457	973	3379	650	229	7104	59646
<b>Blankets</b>	33628	31499	22129	16700	1850	3012	4550	3500	18671	59646
<b>Hygiene Kits</b>	20000	2198	2900	1698	2434	776	650	0	30002	60658
<b>Kitchen Sets</b>	9516	5290	1451	3396	0	0	650	0	6026	26329
<b>Plastic Sheets</b>	3029	23268	5898	2720	5490	728	1300	80	15753	58266
<b>Lamp Hurricanes</b>	593	7428	3100	2112	2450	610	650	0	16808	33751
<b>Stoves</b>	1700	19753	6764	2298	723	450	650	0	10148	42486
<b>Jerry Cans</b>	1532	9998	3011	2820	3117	577	1050	500	18243	40848
<b>Shelter Kits</b>	1925	1672	0	0	0	0	0	0	0	3597
<b>Jackets</b>	2036	96137	0	0	0	0	0	0	899	99072
<b>Sleeping Bags</b>	943	16101	1957	2990	2067	159	0	0	753	24970
<b>Quilts</b>	4090	4259	0	0	0	0	0	700	732	9781
<b>Coffen Rolls</b>	9	1500	1500	600	1500	1000	900	0	0	7009
<b>Bucket Plastic</b>	0	0	0	0	0	0	0	0	9830	9830

**OXFAM**

<b>Location</b>	<b>Generators</b>	<b>Health &amp; Hygiene Kits</b>	<b>Water Purification Kits</b>	<b>Plastic Sheets</b>	<b>Plastic Sacks</b>	<b>Sanitation Kits</b>	<b>Water Pumps</b>
Islamabad	3	-	-	-	-	492	6
Punjab	-	1435	-	1125	7797	-	-
Sindh	-	7345	2400	2746	26800	-	-
<b>Total</b>	<b>3</b>	<b>8780</b>	<b>2400</b>	<b>3871</b>	<b>34597</b>	<b>492</b>	<b>6</b>

**MUSLIM AID**

<b>Location</b>	<b>Tents</b>	<b>Blankets</b>	<b>Jerry Cans</b>	<b>Aqua Tabs</b>	<b>Water Tanks</b>	<b>Hosp Shelter</b>
Islamabad	200	200	400	23,50,000	2	1
<b>Total</b>	<b>200</b>	<b>200</b>	<b>400</b>	<b>23,50,000</b>	<b>2</b>	<b>1</b>